

814-S87 SafeSupport® SR™ Access Panels

MATERIAL: 12 gauge steel door and frame.

OPTIONS:

Paintable galvanized steel - mill finish.
Stainless steel - satin polish.

HINGE: Concealed continuous piano hinge.

LATCH: Pinned allen head security cam latch.

OPTIONS:

Key operated cylinder lock cam latch.
Key operated cylinder dead bolt lock.
Prep for cylinder lock by others.
Detention lock.
Prep for detention lock by others.

MOUNTING: 1/4" mounting holes in frame.

OPTIONS:

Factory installed masonry anchors.
12 guage sleeve with drywall bead in lieu of flanged frame.

FINISH: Two part polyurethane primer/white finish coat.

OPTION:

Two part polyurethane primer/white finish coat on paintable galvanized steel.

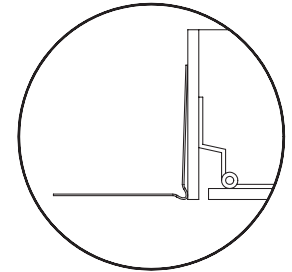

OPTIONAL DRYWALL BEAD DETAIL

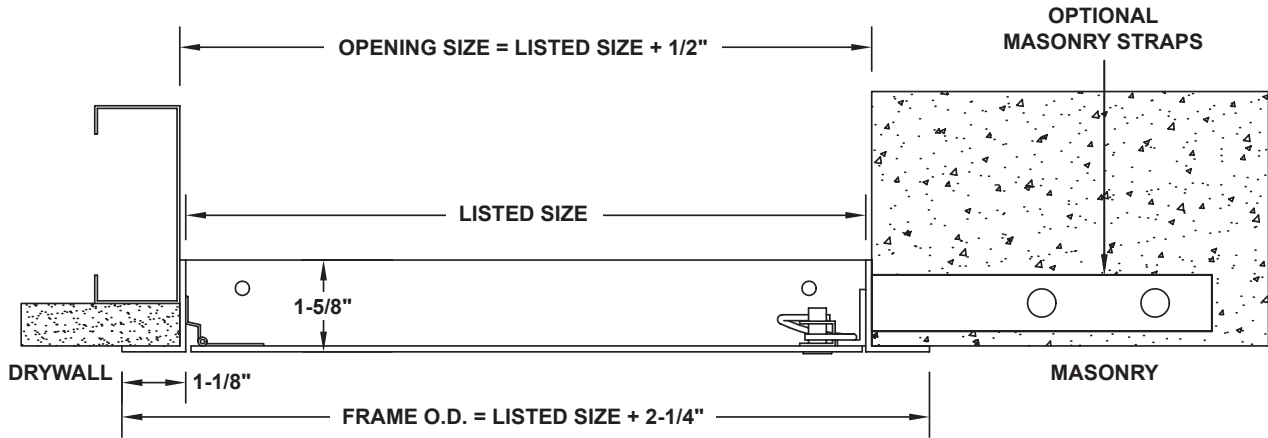

Qty.	Door Size		Frame O.D.		Wall Opening		No. of Latches	Options	Tag
	Width	Height	Width	Height	Width	Height			
	8	8	10-1/4	10-1/4	8-1/2	8-1/2	1		
	10	10	12-1/4	12-1/4	10-1/2	10-1/2	1		
	12	12	14-1/4	14-1/4	12-1/2	12-1/2	1		
	14	14	16-1/4	16-1/4	14-1/2	14-1/2	1		
	16	16	18-1/4	18-1/4	16-1/2	16-1/2	1		
	18	18	20-1/4	20-1/4	18-1/2	18-1/2	1		
	24	24	26-1/4	26-1/4	24-1/2	24-1/2	4		
	24	36	26-1/4	38-1/4	24-1/2	36-1/2	5		
	24	48	26-1/4	50-1/4	24-1/2	48-1/2	5		
	30	30	32-1/4	32-1/4	30-1/2	30-1/2	5		
	36	36	38-1/4	38-1/4	36-1/2	36-1/2	5		
	36	48	38-1/4	50-1/4	36-1/2	48-1/2	5		

Project		Location	
Engineer			
Architect		Dwg. No.	
Contractor		Date	04/13